



Part No. 2321-0121

K1903 070609

Honda VTX1800 Chrome covered forks.  
2002 to 2008  
MS Batwing Cruiser Fairing Mounting Kit

**CAUTION!**  
GAS TANK DAMAGE WILL OCCUR  
on some versions of this model if fork  
clamps are installed too high on the forks

 **WARNING**

1. During installation, make sure that the fairing and hardware do not interfere with any cables or wiring when the forks are turned all the way in either direction. Also make sure, through the full range of adjustment, that the fairing and hardware do not hit the gas tank.
2. If the adjustable clamps are installed backwards, it will result in serious gas tank damage. Always check for proper gas tank clearance before tightening hardware.
3. This is a detachable fairing, always make sure the locking mechanism is fully engaged after installing the fairing.
4. The improper installation of this kit and related components could result in serious injury or death.

 **CAUTION**

1. Memphis Shades fairings and Lowers are made from Lucite® acrylic, and will last for years with proper care. Clean your fairing with plenty of soapy water (mild dishwashing liquid is best) and a soft cotton cloth. Use your bare hands to feel and dislodge bugs, or cover with a wet, soapy towel and let it soak. Don't use paper towels and scrape with anything. Small scratches can be removed with NOVUS #2.
2. Never use any glass cleaning products, petroleum based chemicals, or cleaning agents with ammonia, bleach or any other harsh chemicals. This includes (but not limited to) RainX, brake fluid, acetone, paint thinner, benzene and gasoline. "If it hurts your nose, it will hurt the plastic."
3. Glass cleansing agents will cause severe damage to your fairing, and will void your warranty.
4. At certain times of the day the sunlight can reflect off the curvature of a fairing and cause extreme heat build up on motorcycle instruments and instrument panel. Take care when parking. Park facing the sun, place an opaque object over the instruments or adjust the fairing to avoid reflections

## 1. Kit Contents

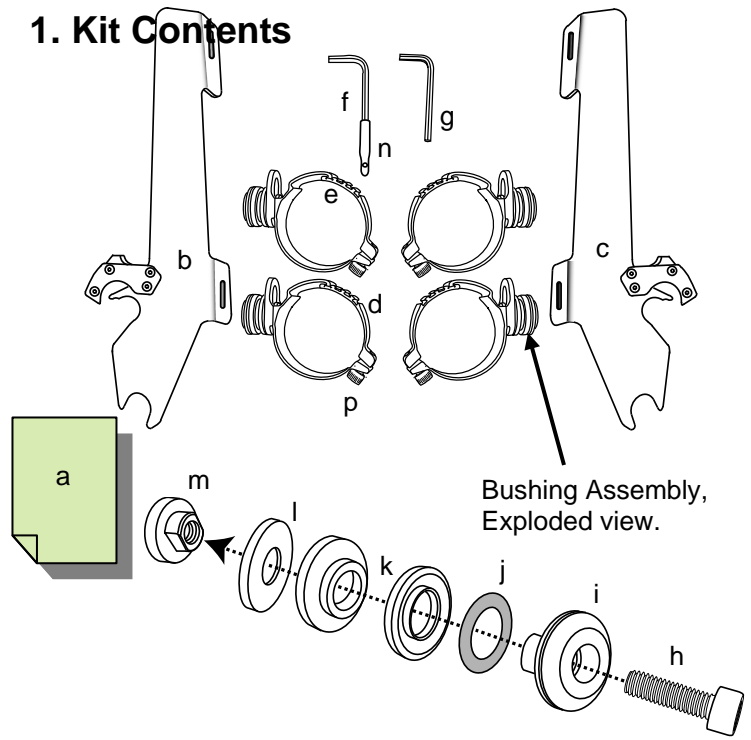

Bushing Assembly,  
Exploded view.

Ref	Part #	Description	Qty
(a)	K1903	Mounting Instructions	1
(b)	M1274	Clutch side Plate Assembly	1
(c)	M1275	Throttle side Plate Assembly	1
(d)	M533	M Outer Clamp, Detachable, with tape	4
(e)	M523	Large, Inner Adjustable Clamp, with tape	4
(f)	M310	3/16" Short Arm Allen Wrench	1
(g)	R352	1/8" Short Arm Allen Wrench	1
(h)	M306	1/4-20x5/8" SS Socket Head Cap Screw	4
(i)	R318	1" Socket Shoulder Washer	4
(j)	R324	#207 O Ring, EPDM	4
(k)	R323	Bushing Assembly (2 piece)	4
(l)	M369	0.75x0.25x0.036 SS Washer	4
(m)	R329	5/8" Slot Nut	4
(n)	M313	3/16" Allen Wrench Cover	1
(p)	R351	1/4-20x3/4" SS Low Head Socket Screw	4

Memphis Shades warrants all product components, metal and plastic, against defects in materials and workmanship for 24 months.

### For Parts and Warranty Help, Contact:

Memphis Shades, Inc.  
P.O. Box 429  
Rossville, TN 38066  
(901) 853 0293

Visit us on the web at [www.memphisshades.com](http://www.memphisshades.com) or you can also reach us by email:

[customerservice@memphisshades.com](mailto:customerservice@memphisshades.com)

Honda VTX1800 Chrome covered forks.  
2002 to 2008  
MS Batwing Cruiser Fairing Mounting Kit

## 2. Mounting Instructions

**CAUTION!**  
**GAS TANK DAMAGE WILL OCCUR**  
on some versions of this model if fork  
clamps are installed too high on the forks

1. Additional tools required, not included in this kit:  
7/16" or 11mm wrench.
2. **Cover the gas tank and front fender with towels to  
Avoid damage during installation.**
3. Install the two mounting plates onto the fairing, using  
the acorn nuts and washers supplied with the fairing.  
(See Fig 1)
4. Loosely install the fork clamps, approximately 1 3/4"  
apart, with the lower clamps touching the lower triple  
tree. (See Fig 2)
5. Start with each fork clamp bushing adjusted to the rear  
of the slot. (See Fig 3)
6. Slip the fairing mounting plates and fairing onto the fork  
clamp bushing. (See Fig 4)
7. Secure the Left and Right side Trigger Lock, locking  
mechanism. (Fig 5)
8. Adjust the height, angle and alignment of the  
fairing then tighten **all** bolts

Fig 1

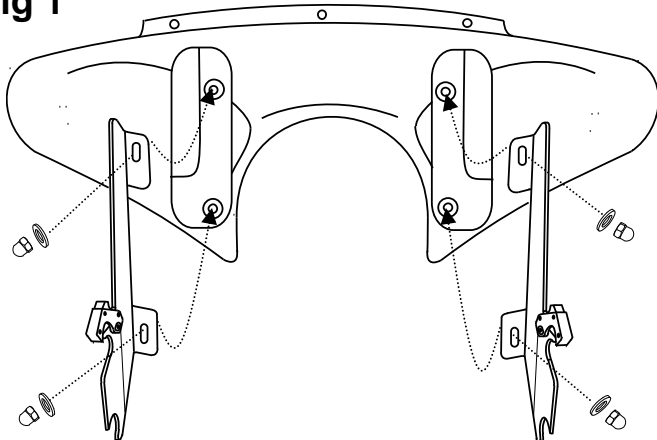

Fig 2

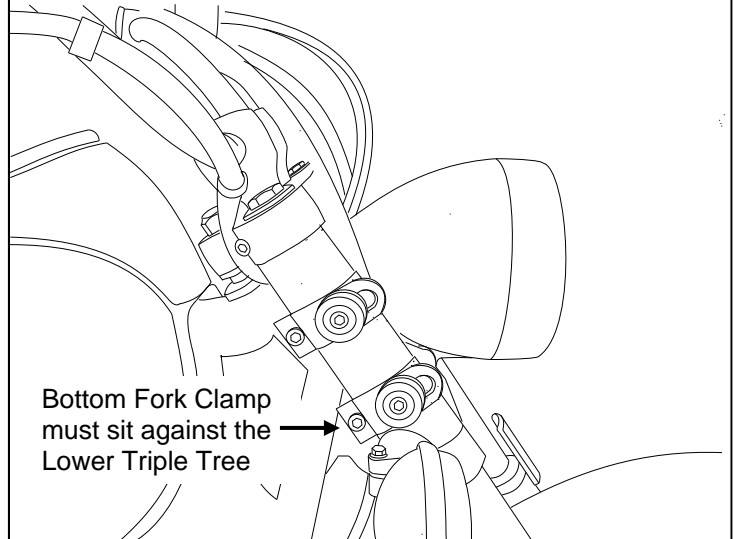

Fig 3

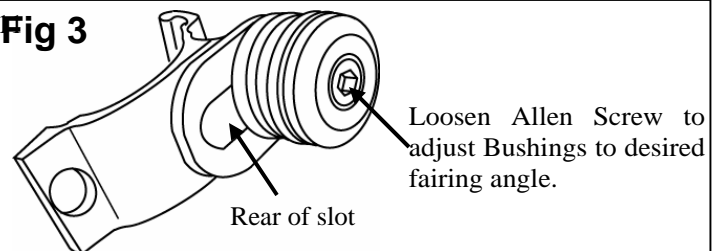

Fig 4

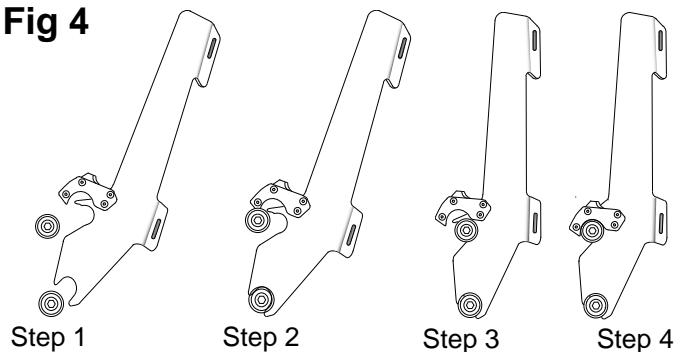

Fig 5

