



MOUNTING INSTRUCTIONS



2321-0078 FATS/SLIMS 9" HDLT. PLATES ONLY SUZUKI VOLUSIA C-50 800

▲ WARNING

Read and follow these directions carefully.

During installation, make sure that the windshield and hardware do not interfere with any cables or wiring when the forks are turned all the way in either direction. Also make sure, through the full range of adjustment, that the windshield and hardware do not hit the tank.

This is a detachable windshield, **ALWAYS** make sure the Locking Mechanism is Fully Engaged after installing the windshield!

The improper installation of this kit and related components could result in serious injury or death.

1. Cover gas tank and front fender with towels to avoid damage during installation.
2. Install the two mounting plates onto the windshield, using the bottom and third bolt up. Leave the nylon washers off. The small tab goes to the bottom, big one at the top. *Tabs point out towards the edge of the windshield.* (see fig. 1)
3. Slip the windshield brackets into the bushings, adjust height and angle. Now tighten all mounting all bolts. (see fig. 2 and 3)

Note: This is a detachable windshield, **ALWAYS** make sure the Locking Mechanism is Fully Engaged after installing the windshield! (see figure 4)

CAUTION

IMPORTANT CARE AND CLEANING INSTRUCTIONS

Memphis Shades Windshields and Loweres are made of Lucite® acrylic, and will last for years with proper care. Clean your windshield with plenty of soapy water — mild dishwashing liquid is best — and a soft cotton cloth. Use your bare hand to feel and dislodge bugs, or cover with a wet soapy towel and let it soak. Don't use paper towels and don't scrape with anything. Small scratches can be removed with NOVUS # 2.

NEVER use any glass cleaning products, petroleum based chemicals, or cleaning agents with ammonia, bleach or any other harsh chemicals. This includes (but not limited to) RainX, brake fluid, acetone, paint thinner, benzene and gasoline. "If it hurts your nose, it will hurt the plastic."

Glass cleansing agents will cause severe damage to your windshield, and will void your warranty.

NOTE: At certain times of the day the Sunlight can reflect off the curvature of a windshield and cause extreme heat build-up on motorcycle instruments and instrument panel. Take care when parking. Park facing the sun, place an opaque object over the instruments or adjust the windshield to avoid reflections.

Fig. 1

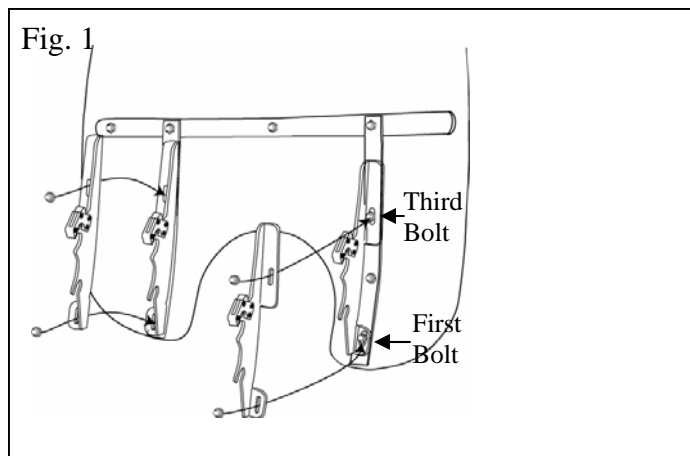
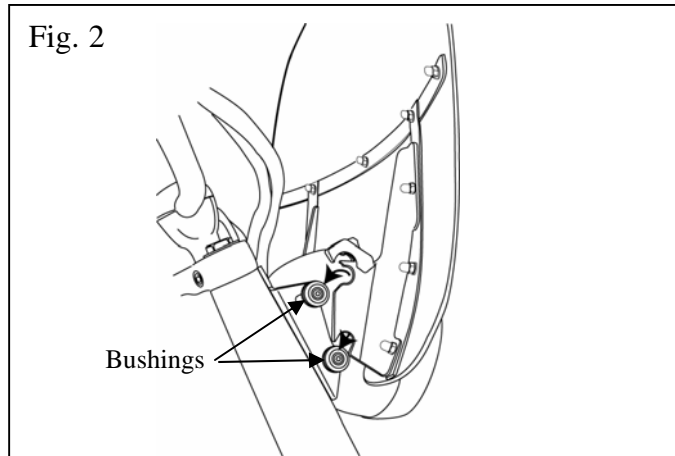

Fig. 2





MOUNTING INSTRUCTIONS



2321-0078 FATS/SLIMS 9" HDLT. PLATES ONLY SUZUKI VOLUSIA C-50 800

Part #	Description	Qty
M8879	Mounting Instructions	1
M1182	Left Mounting Plate Fats / Slims	1
M1183	Right Mounting Plate Fats / Slims	1
R322C	Clutch Side Latch Assembly	1
R322T	Throttle Side Latch Assembly	1
R334	6-32x3/8" Flat Head SS Screw	8
R326	SS Spring	2

Figure 3

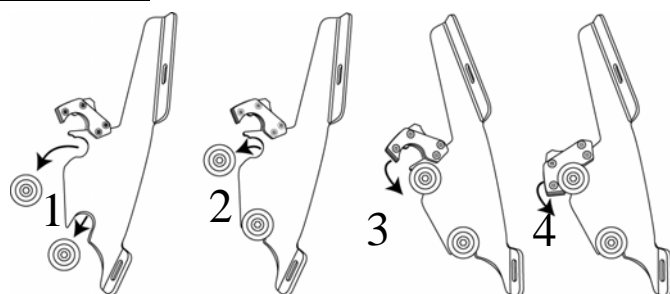

1. Place lower slot into lower bushing. 2. Rotate top slot into place. 3. & 4. Secure locking Mechanism.

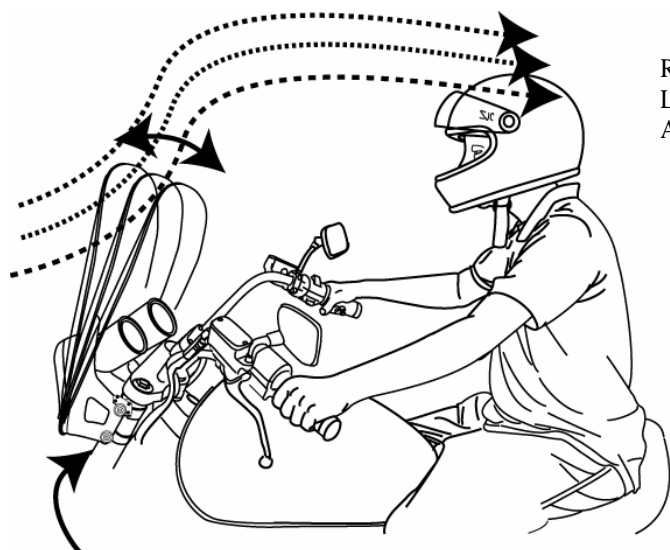

Loosen Allen Bolt to adjust angle, then re-tighten Allen Bolt

Figure 4

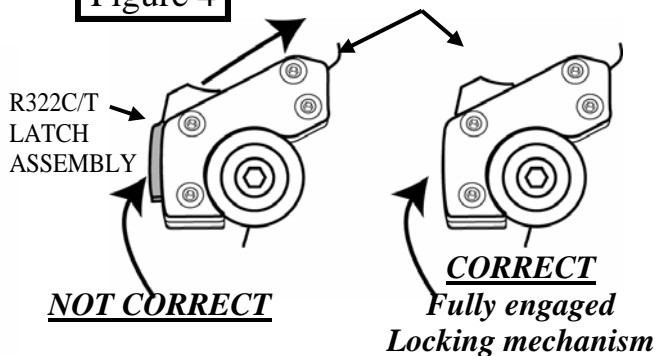

Memphis Shades warrants all product components, metal and plastic, against defects in materials and workmanship for 24 months.

FOR PARTS AND WARRANTY HELP, CONTACT:

MEMPHIS SHADES
P. O. Box 429
Rossville, TN 38066
(901) 853-0293

Visit us on the web at www.memphisshades.com or
you can also reach us at
customerservice@memphisshades.com