



MOUNTING INSTRUCTIONS

2320-0021 Detachable Fats/Slims Mounting Kit for H-D Covered Forks with Light Bar

! WARNING

Read and follow these directions carefully.

During installation, make sure that the windshield and hardware do not interfere with any cables or wiring when the forks are turned all the way in either direction. Also make sure, through the full range of adjustment, that the windshield and hardware do not hit the tank.

This is a detachable windshield, ALWAYS make sure the Locking Mechanism is Fully Engaged after installing the windshield!

The improper installation of this kit and related components could result in serious injury or death.

Additional tools required, that are not included in this kit. 1/2" wrench, 7/16" wrench.

1. Cover gas tank and front fender with towels to avoid damage during installation.

2. Remove the two original upper Light Bar bolts located on the sides of the forks, also temporarily remove the steel spacers behind the Light Bar frame. Replace the bolts with the new longer upper mount bushing assemblies (use the 1-3/4" long bolt assemblies) and re-install the original steel spacers behind the Light Bar frame. (See figure 1) **Note:** Additional 1 1/2" bolts are included for some applications.

3. Remove the two lower Light Bar mounting bolts located on both sides of the forks. Install the new lower bolt bushing assembly. (See figure 1) Repeat step 2 and 3 on the opposite side.

4. Attach the windshield to the windshield mounting plates using the bottom and third bolt on each side. Leave the Nylon washers off. The Mounting tabs should be pointing in towards the headlight when installed correctly. (See Figure 2)

5. Slip the windshield mounting plates and windshield onto the upper and lower bushing assemblies, (see figure 3 and 5) and secure the left and right side locking mechanism.

6. Adjust the height, angle and alignment of the windshield

Note: This is a detachable windshield, ALWAYS make sure the Locking Mechanism is Fully Engaged after installing the windshield! (see figure 5)

CAUTION

IMPORTANT CARE AND CLEANING INSTRUCTIONS

Memphis Shades Windshields and Lowers are made of Lucite® acrylic, and will last for years with proper care. Clean your windshield with plenty of soapy water — mild dishwashing liquid is best — and a soft cotton cloth. Use your bare hand to feel and dislodge bugs, or cover with a wet soapy towel and let it soak. Don't use paper towels and don't scrape with anything. Small scratches can be removed with NOVUS # 2.

NEVER use any glass cleaning products, petroleum based chemicals, or cleaning agents with ammonia, bleach or any other harsh chemicals. This includes (but not limited to) RainX, brake fluid, acetone, paint thinner, benzene and gasoline. "If it hurts your nose, it will hurt the plastic."

Glass cleansing agents will cause severe damage to your windshield, and will void your warranty.

NOTE: At certain times of the day the Sunlight can reflect off the curvature of a windshield and cause extreme heat build-up on motorcycle instruments and instrument panel. Take care when parking. Park facing the sun, place an opaque object over the instruments or adjust the windshield to avoid reflections.

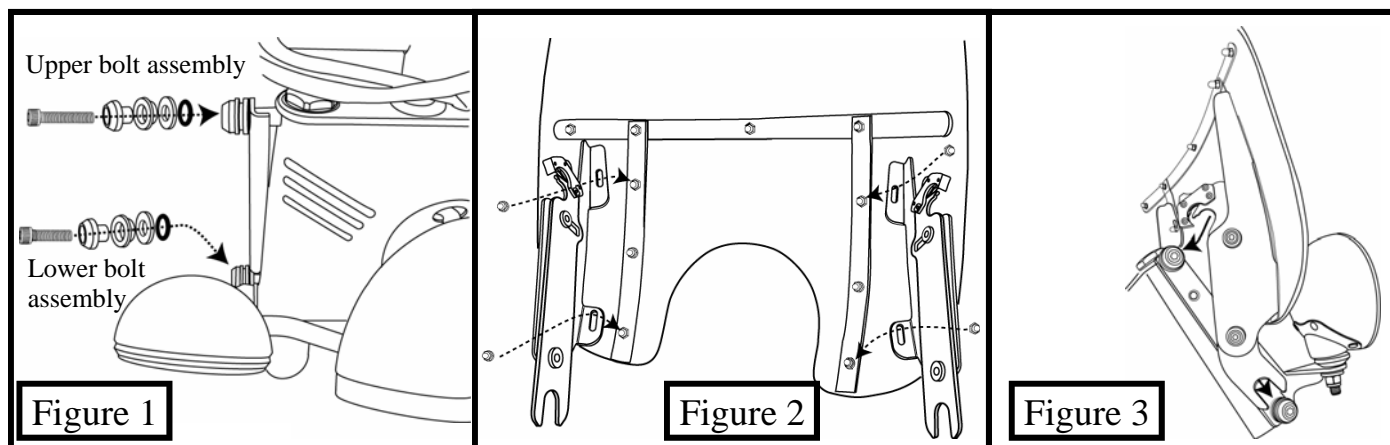



MOUNTING INSTRUCTIONS

2320-0021 Detachable Fats/Slims Mounting Kit for H-D Covered Forks with Light Bar

PART #	DESCRIPTION	QTY.
M8971	MOUNTING INSTRUCTIONS/PARTS LIST	1
M1147	LEFT MOUNTING PLATE FATS/SLIMS	1
M1148	RIGHT MOUNTING PLATE FATS/SLIMS	1
R323	BUSHING ASSEMBLY (2 PART)	4
R324	#207 EPDM O-RING	4
R339	5/16"-24 x 1 3/4" SS SOCKET HEAD CAP SCREW	2
M576	7/8" BEVELED SOCKET WASHER	4
M334	5/16"-24 x 1 1/4" SS SOCKET HEAD CAP SCREW	2
M578	SELF ADHESIVE PLASTIC WASHER	4
R329	SLOT NUT	4

PART #	DESCRIPTION	QTY.
M501	3/4" BEVELED SOCKET WASHER	4
M301	1/4" - 20 X 3/8" SOCKET HEAD CAP SCREW	4
R322c/tS	SLANT LATCH ASSEMBLY	2
R326	LATCH SPRING	2
R334	LATCH SCREW	8
R340	1/4" SHORT ARM ALLEN WRENCH	1
M310	3/16" SHORT ARM ALLEN WRENCH	1
M313	3/16" ALLEN WRENCH COVER	1
M361	5/16"-24 x 1 1/2" SS SOCKET HEAD CAP SCREW	2

BUSHING ASSEMBLY

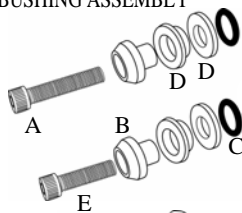

- A. R339
- B. M576
- C. R324
- D. R323
- E. M334

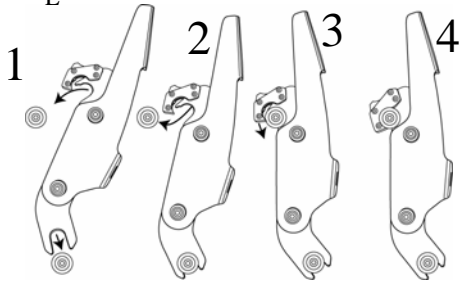

1. Place lower slot into lower bushing. 2. Rotate top slot into place. 3. & 4. Secure locking Mechanism.

Figure 5

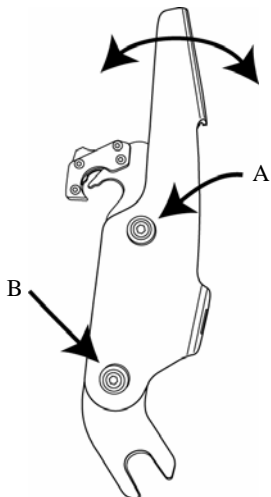

Loosen Allen Bolts A & B to adjust angle, then re-tighten Allen Bolts.

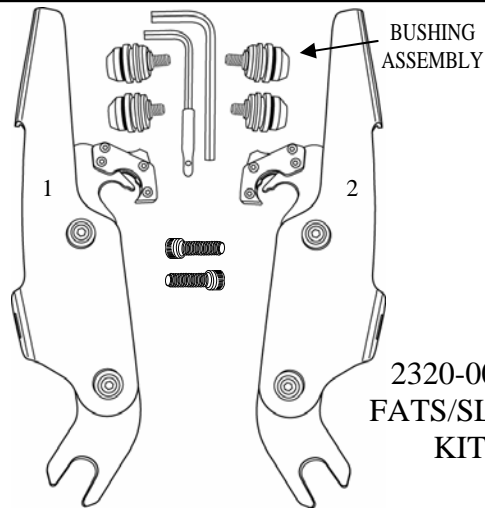

2320-0021
FATS/SLIMS
KIT

R322c/tS
SLANT
LATCH
ASSEMBLY

NOT CORRECT

CORRECT
Fully engaged

Memphis Shades warrants all product components, metal and plastic, against defects in materials and workmanship for 24 months.

FOR PARTS AND WARRANTY HELP, CONTACT:

MEMPHIS SHADES
P. O. Box 429
Rossville, TN 38066
(901) 853-0293

Visit us on the web at www.memphisshades.com or
You can also reach us at
customerservice@memphisshades.com