



MOUNTING INSTRUCTIONS



2321-0063 FATS/SLIMS MOUNTING KIT HONDA VTX 1300 C

⚠ WARNING

Read and follow these directions carefully. During installation, make sure that the windshield and hardware do not interfere with any cables or wiring when the forks are turned all the way in either direction. Also make sure, through the full range of adjustment, that the windshield and hardware do not hit the tank.

This is a detachable windshield, **ALWAYS** make sure the Locking Mechanism is Fully Engaged after installing the windshield!

The improper installation of this kit and related components could result in serious injury or death.

Additional tools required, that are not included in this kit. 7/16" or 11mm wrench.

1. Cover gas tank and front fender with towels to avoid damage during installation.
2. Install the two mounting plates onto the windshield, using the bottom and third bolt up. Leave the nylon washers off. The small tab goes to the bottom, big one at the top. (see Figure 1) *Tabs face in towards the headlight when installed correctly.*

WARNING

If the adjustable clamps are installed backwards, it will result in serious gas tank damage. Always check for proper gas tank clearance before tightening hardware. (see Figure 2)

3. Loosely install the four Fork Clamps on the forks, approximately 2" apart. (see figure 2)
4. Start with Fork Clamp Bushing adjusted to rear of slot (see figure 4) Then adjust as needed and check for clearance. (See warning above.)
5. Slip the windshield mounting plates and windshield onto the fork clamps, (see figure 3 and 5) and secure the left and right side locking mechanism
6. Adjust the height, angle and alignment of the windshield and tighten **ALL** bolts.

Note: This is a detachable windshield, **ALWAYS** make sure the Locking Mechanism is Fully Engaged after installing the windshield! (see figure 5)

CAUTION

IMPORTANT CARE AND CLEANING INSTRUCTIONS

Memphis Shades Windshields and Loweres are made of Lucite® acrylic, and will last for years with proper care. Clean your windshield with plenty of soapy water — mild dishwashing liquid is best — and a soft cotton cloth. Use your bare hand to feel and dislodge bugs, or cover with a wet soapy towel and let it soak. Don't use paper towels and don't scrape with anything. Small scratches can be removed with NOVUS # 2.

NEVER use any glass cleaning products, petroleum based chemicals, or cleaning agents with ammonia, bleach or any other harsh chemicals. This includes (but not limited to) RainX, brake fluid, acetone, paint thinner, benzene and gasoline. "If it hurts your nose, it will hurt the plastic."

Glass cleansing agents will cause severe damage to your windshield, and will void your warranty.

NOTE: At certain times of the day the Sunlight can reflect off the curvature of a windshield and cause extreme heat build-up on motorcycle instruments and instrument panel. Take care when parking. Park facing the sun, place an opaque object over the instruments or adjust the windshield to avoid reflections.

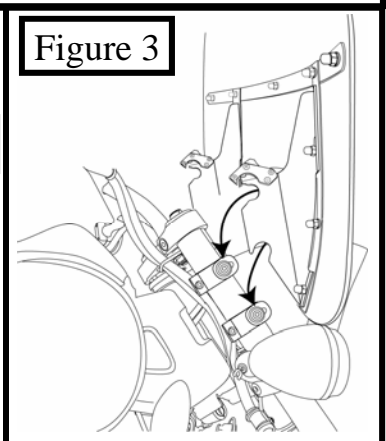
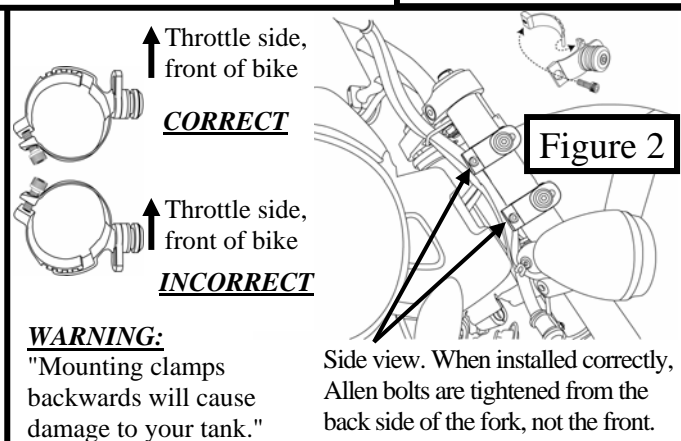
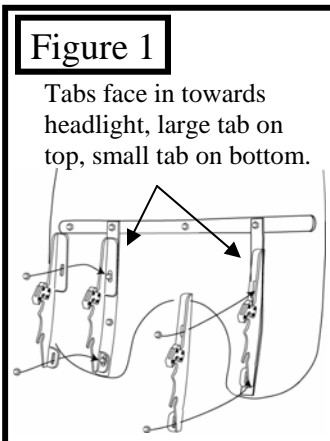
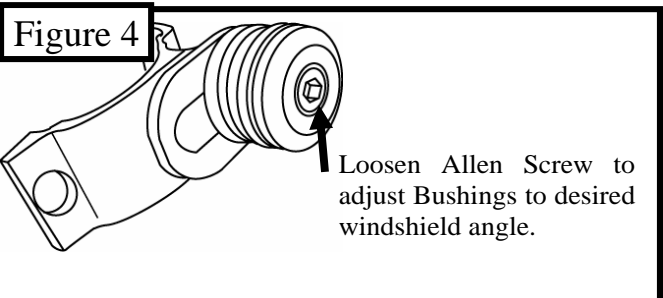



MOUNTING INSTRUCTIONS



2321-0063 FATS/SLIMS MOUNTING KIT HONDA VTX 1300 C

PART #	DESCRIPTION	QTY.
M8973	MOUNTING INSTRUCTIONS/PARTS LIST	1
M1161	LEFT MOUNTING PLATE FATS/SLIMS	1
M1160	RIGHT MOUNTING PLATE FATS/SLIMS	1
R323	BUSHING ASSEMBLY (2 PART)	4
R324	#207 EPDM O-RING	4
R318	1" SOCKET SHOULDER WASHER	4
M306	1/4" - 20 X 5/8" SOCKET HEAD CAP SCREW	4
R329	SLOT NUT	4
M369	STAINLESS STEEL WASHER	4

PART #	DESCRIPTION	QTY.
M520	INNER ADJ. FORK CLAMP HALF	4
M532	OUTER DETACHABLE ADJ. FORK CLAMP HALF	4
M303	1/4" - 20 X 3/4" SOCKET HEAD CAP SCREW	4
R322C/T	LATCH ASSEMBLY	2
M310	3/16" SHORT ARM ALLEN WRENCH	1
M313	3/16" ALLEN WRENCH COVER	1
M314	3/16" T-HANDLE ALLEN WRENCH	1
M337	3/16" T-HANDLE ALLEN WRENCH COVER	1

Figure 5

BUSHING ASSEMBLY

A. R329
B. M369
C. R323
D. R324
E. R318
F. M306

1. M532
2. M520
3. M1160
4. M1161

2321-0063 FATS/SLIMS KIT

NOT CORRECT **CORRECT Fully engaged**

Loosen Allen Bolt to adjust angle, then re-tighten Allen Bolt.

Memphis Shades warrants all product components, metal and plastic, against defects in materials and workmanship for 24 months.

FOR PARTS AND WARRANTY HELP, CONTACT:
MEMPHIS SHADES
P. O. Box 429
Rossville, TN 38066
(901) 853-0293

Visit us on the web at www.memphisshades.com or
You can also reach us at
customerservice@memphisshades.com