



# MOUNTING INSTRUCTIONS

## 2321-0112 ROADLINER FAIRING MOUNTING KIT, BLACK

### **! WARNING**

1. During installation, make sure that the fairing and hardware do not interfere with any cables or wiring when the forks are turned all the way in either direction. Also make sure, through the full range of adjustment, that the fairing and hardware do not hit the gas tank.
2. This is a detachable fairing, ALWAYS make sure the locking mechanism is fully engaged after installing the fairing.
3. The improper installation of this kit and related components could result in serious injury or death.

Additional tools required that are not included in this kit.  
7/16" or 11mm Wrench.

1. **Cover gas tank and front fender with towels to avoid damage during installation.**
2. Install the two mounting plates onto the fairing using the black washer and acorn nut supplied with the fairing. ( Fig 1). *Tabs point in towards the edge of the headlight.*
3. Using a 5mm Allen wrench. Locate and remove the two upper Allen head bolts, one on each side of the headlight. Save these bolts to install brackets. (see figure 2)
4. Install the right side bracket by placing the support washer into the upper hole "the large part faces out, the small part faces in" followed by the bracket and then loosely re-install one of the upper bolts that was removed earlier. (see figure 2)
5. Locate and remove the two unused bolts in the lower triple tree, one on each side of the headlight and discard. Install the lower screw by inserting one of the new 8mm x 30mm button head screws in this order, through the bracket, through the spacer and tighten the lower and upper bolt.
6. Repeat step 5 for the left side bracket. (see figure 2)
7. Install the fairing by placing the lower slots into the lower mounting bushings. Slip the upper slots into the upper mounting bushings and gently but firmly seat the slots into place. Lock the locking mechanism into place. (see figure 3 and 4)

8. Adjust the height, angle and alignment of the fairing and tighten **ALL** bolts.

**Note:** This is a detachable fairing, **ALWAYS** make sure the **Locking Mechanism is Fully Engaged** after installing the fairing! (see figure 4)

### **CAUTION**

#### IMPORTANT CARE AND CLEANING INSTRUCTIONS

Memphis Shades Fairings and Loweres are made of Lucite® acrylic, and will last for years with proper care. Clean your fairing with plenty of soapy water — mild dishwashing liquid is best — and a soft cotton cloth. Use your bare hand to feel and dislodge bugs, or cover with a wet soapy towel and let it soak. Don't use paper towels and don't scrape with anything. Small scratches can be removed with NOVUS # 2.

**NEVER** use any glass cleaning products, petroleum based chemicals, or cleaning agents with ammonia, bleach or any other harsh chemicals. This includes (but not limited to) RainX, brake fluid, acetone, paint thinner, benzene and gasoline. "If it hurts your nose, it will hurt the plastic."

**Glass cleansing agents will cause severe damage to your fairing, and will void your warranty.**

**NOTE:** At certain times of the day the Sunlight can reflect off the curvature of a fairing and cause extreme heat build-up on motorcycle instruments and instrument panel. Take care when parking. Park facing the sun, place an opaque object over the instruments or adjust the fairing to avoid reflections.

Figure 1

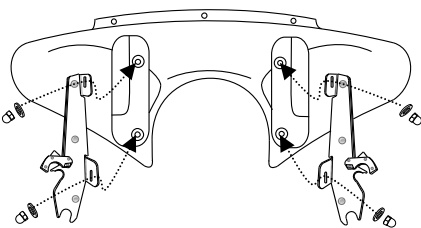

Figure 2

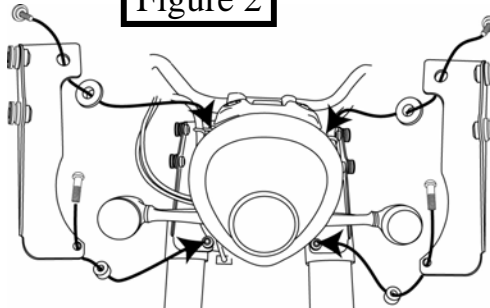
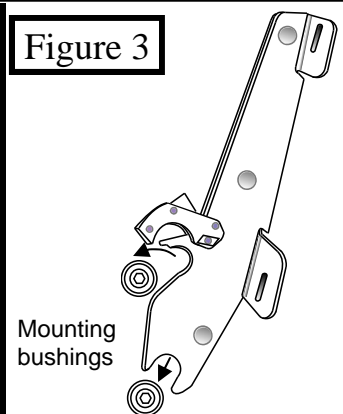

Figure 3





# MOUNTING INSTRUCTIONS

## 2321-0112 ROADLINER FAIRING MOUNTING KIT, BLACK

Part #	Description	Qty
M8997	Mounting Instructions	1
M1225	Clutch side mounting plate, black	1
M1226	Throttle side mounting plate, black	1
M1087	Left bracket	1
M1088	Right bracket	1
R318	1" Socket shoulder spacer	4
R323	Bushing assembly (2 part)	4
R324	#207 EPDM O ring	4
M303	1/4"-20x3/4" Socket head cap screw	4
M505	Button nut	4

Part #	Description	Qty
R319	1/2" Spacer	2
R320	1 1/2" Support spacer	2
M366	8mm x 30mm Button head cap screw	2
R322C	Clutch side latch assembly	1
R322T	Throttle side latch assembly	1
R306	5mm Long arm allen wrench	1
M310	3/16" short arm allen wrench	1
M313	3/16" allen wrench cover	1
R321	1" Recessed spacer washer	4

Figure 4

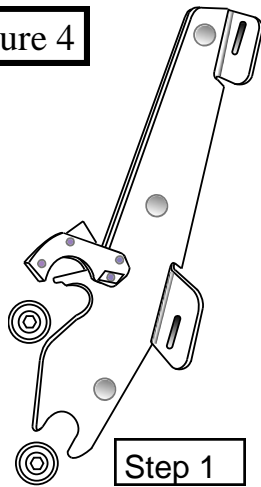

Step 1

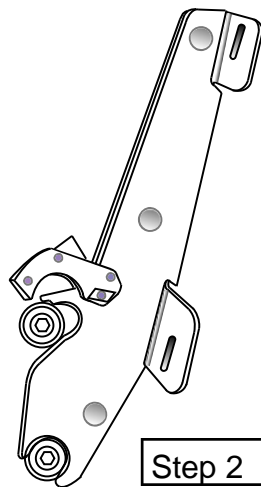

Step 2

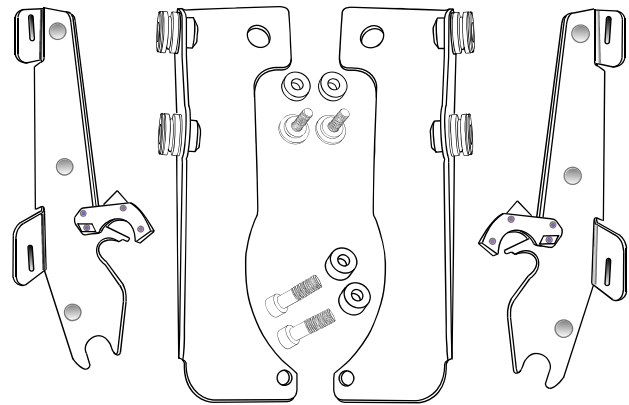

2321-0112 Fairing kit

1. Place lower slot into lower bushing.
2. Rotate top slot into place.
3. Secure locking mechanism.

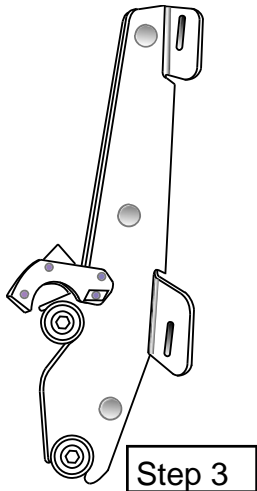

Step 3

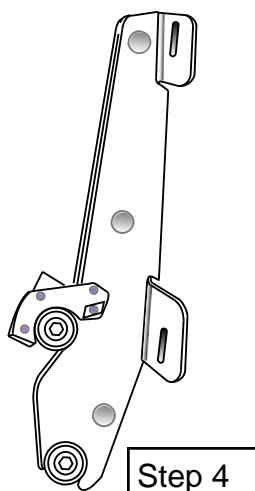

Step 4

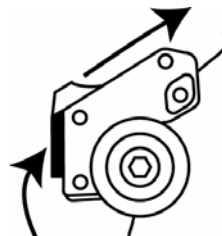

**NOT CORRECT**

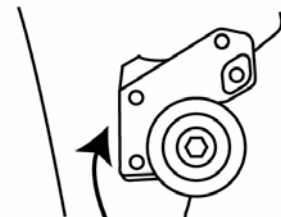

**CORRECT**  
**Fully engaged**

Memphis Shades warrants all product components, metal and plastic, against defects in materials and workmanship for 24 months.

**FOR PARTS AND WARRANTY HELP, CONTACT:**

MEMPHIS SHADES  
P. O. Box 429  
Rossville, TN 38066  
(901) 853-0293

Visit us on the web at [www.memphisshades.com](http://www.memphisshades.com) or  
you can also reach us by email:  
[customerservice@memphisshades.com](mailto:customerservice@memphisshades.com)